

US PRODUCT SHEET

# NORA A



Non contractual picture

AAE NORA PS



Alain Ellouz  
.paris

<b>Type</b>	Mirror
<b>Environment</b>	Indoor
<b>Material</b>	Alabaster
<b>Lighting system</b>	LED Strip 2,9 W/ft - Dimmable intensity (2700K or 3000K) - Remoted transformer
<b>Lighting control system</b>	To be chosen according to project
<b>Wattage</b>	NORA A140 : 40W NORA A160 : 48W
<b>Voltage</b>	24V : transformer provided
<b>Luminous flux</b>	Source : NORA A140 : 3135 lm NORA A160 : 3700 lm The alabaster diffuses between 40 and 60% of the light source lumens
<b>Weight</b>	NORA A140 : Approx. 66,14 lbs NORA A160 : Approx. 79,37 lbs

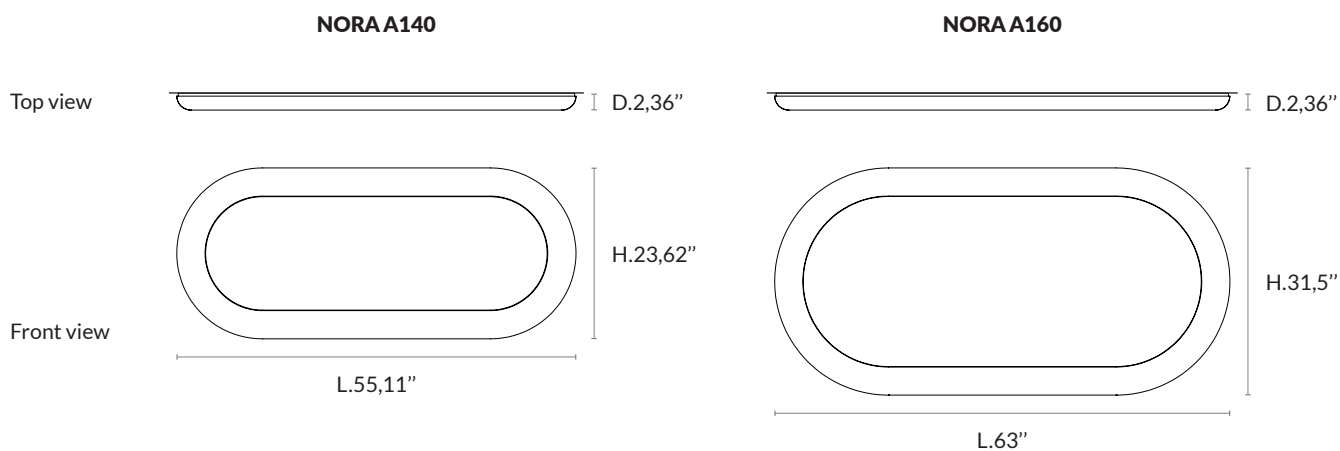

## LIGHTING CONTROL SYSTEM

To be chosen according to project : DMX, DALI (DT8), TRIAC (phase dimming, setting knobs to choose the light temperature), 1-10V (two 1-10V bus required), NONE (setting knob to choose and fix the light intensity and temperature).

For a correct functioning the remote transformer / driver must be placed in an accessible place at maximum 33' from the light fixture.

NORA A<sup>®</sup>  
DESIGN BY ATELIER ALAIN ELLOUZ  
MADE IN FRANCE

**References** HSP-0038

**Warranty** 2 years warranty. General terms and conditions of sale

[www.atelieralainellouz.com](http://www.atelieralainellouz.com), [contactusa@atelieralainellouz.com](mailto:contactusa@atelieralainellouz.com), +1 (212) 381 6172